

FULL RANGE OF HIGH PERFORMANCE COST EFFECTIVE COMPACT DESIGNS



Low Sample Coolers: - (Originally developed in association with CEGB), have been the de facto standard for many years in nearly all UK Power Stations and with UK plant builders for both UK and overseas projects. Their performance and reliability remain unsurpassed. Ever conscious of changing markets LOWE has introduced a wider and upgraded range, retaining many of the outstanding features whilst offering more cost effective solutions.

Large heat capacity: - With very low cooling water pressure drop, allowances for coil & shell fouling at full process conditions resulting in a safely predictable performance with high sample flow rates and minimum coil vibration. Short sample residence time reduces the build-up of solids and scale.

Sealing: - single non asbestos bearing gasket only

Coils designed to minimise thermal shock:

Reducing stress corrosion and extending coil life. This unique feature has been retained for this new range.

Shell removable: -without disturbing the sample lines, for inspection or maintenance purposes to the most commonly fouled area.

Heat Treated Coils: - offered as standard to extend coil life even further. Alternative materials to the standard Stainless Steel coils are available i.e. INCONEL or MONEL where more aggressive conditions prevail.

Shell Relief Valves: - Available from Thermal Relief Valve to Full Flow protection, if required against the unlikely event of simultaneous guillotine coil failure

Special Designs: - for Low Pressure Steam / Water; Multi Steam samples; Multi element Isothermal Bath Type; High Sample Flow and closer approach tolerances.

APPLICATION NOTES Sample coolers are only one part of the conditioning system and all characteristics of the installation should be taken into account in selecting the optimum cooler e.g. process conditions, siting, transfer pipework runs, heat loss, response time etc. Lowe's experience, in this field is unrivalled and we will be happy to advise you on your particular application.

Coolers are designed for counterflow cooling to achieve very close temperature approach of the sample to the coolant. Some applications require co-current sample flow - please consult the factory for advice.

The most frequently encountered problem is limited permissible cooling water flow differential pressure. Lowe coolers are designed to perform to meet TEMA industry norms for pressure drop and they provide high thermal performance with low demand on cooling water / pressure drop. This also helps reduce problems arising from cavitation, vibration and consequent reduced coil life.

Cooling water quality is an important criterion in performance and life expectancy. The cooler may become fouled over time with consequent impairment of performance. The rate of deterioration will depend on coolant quality. Demineralised water is the preferred coolant and if chlorides are present in either sample or coolant - certainly if in excess of 50ppm - please consult the factory.

Low pressure steam sample flow may be restricted by the overall system pressure drop, creating thermo dynamic choking. For steam pressures below 40 bar A - consult the factory. Special designs are available for critical conditions.

For two stage cooling it is recommended that the primary cooler is selected to reduce the sample temperature to within 10 °C of the primary coolant inlet temperature. This will reduce the heat load on the secondary system which is often required to be cooled by chilled water and will minimise the chiller plant size. Please note special care is required where ambient / coolant temperatures may at times be below 25 ° C

Final approach temperature will depend on application and type of analysis required. Lowe coolers can be selected to provide an approach with 1 ° C if required, but full details will be required for the factory to assess and make recommendations.

For steam samples - we recommend a cooler of not less than .22 sq.m. coil surface area

For other applications and certified performance at specific process conditions - consult factory.

When using the water performance curves please use them as guide only and confirmation should be requested on critical applications and for those with other than water or steam.

Variations in performance can arise due to:

- Sample flow rate variation & temperature excursion.
- Heat transfer in sample carrier lines. LOWE performance curves assume NO HEAT LOSS in transfer pipework from the process.
- Degree of maintenance (fouling) - Note – LOWE cooler performance incorporates an allowance for fouling on both sides of the cooler coil.
- Cooling water flow rates, temperature and quality. Available pressure drop across the cooling water system including all its components.

Lowe Series 7 Sample Cooler Feature:-

- Compact design allowing mounting in various configurations.
- All connections on top flange with optional bottom coolant connection.
- No crevice forming welds between lid and coil which often leads to concentration of impurities, rapid corrosion and failure of the coil by pitting.
- 1/4" & 3/8" o/d coils in Stainless Steel with heat treated option for longer life.
- Inconel or Monel options for aggressive conditions.
- Shell design maximum 30 barg @ 345°C
- Tube design 350 barg @ 538 °C
- Tube material 1/4" o/d 20g & 3/8" o/d 16g 316 Stainless Steel / Monel / Inconel 600.
- Shell & Lid material 304 Stainless Steel.

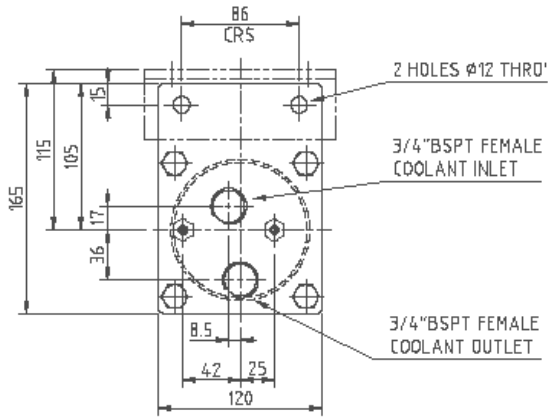

NOTES:

- COOLER COIL MATL OPTIONS:
1/4"OD/6mm ST.ST 316, MONEL 400 OR INCONEL 600
3/8"OD/10mm ST.ST 316, MONEL 400 OR INCONEL 600
- COOLER SHELL MANUFACTURED FROM ST.ST 304
- MOUNTING ATTITUDE VERTICAL
- MOUNTING BRACKET SHOWN THUS ----- IS AVAILABLE AS AN OPTIONAL EXTRA
- TEST PRESSURES IN ACCORDANCE WITH PROCEDURE QP3.01
COIL TO 517 BAR(G) (7500 PSIG)
SHELL TO 10.3 BAR(G) (150 PSIG)

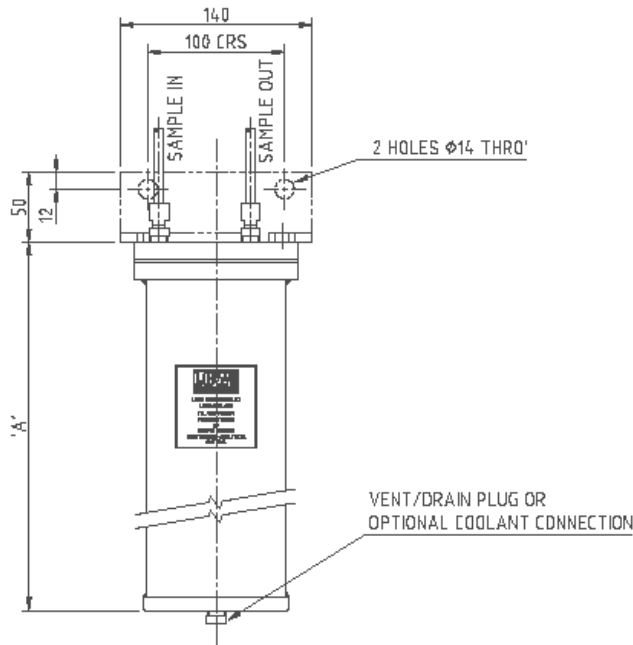

COOLER MODEL	DIMENSION 'A'		WEIGHT
	'A' mm	KG	
7.26.04.6	265	10	
7.26.06.6			
7.26.04.11			
7.35.06.11	355	11.5	
7.35.04.15			
7.44.06.15	445	14	
7.44.04.21			
7.58.06.21	585	17	

COOLER MODEL	COIL SURFACE AREA (sq M)
7.26.04.6	.11
7.26.06.6	.17
7.26.04.11	.22
7.35.06.11	.32
7.35.04.15	.30
7.44.06.15	.46
7.44.04.21	.42
7.58.06.21	.61

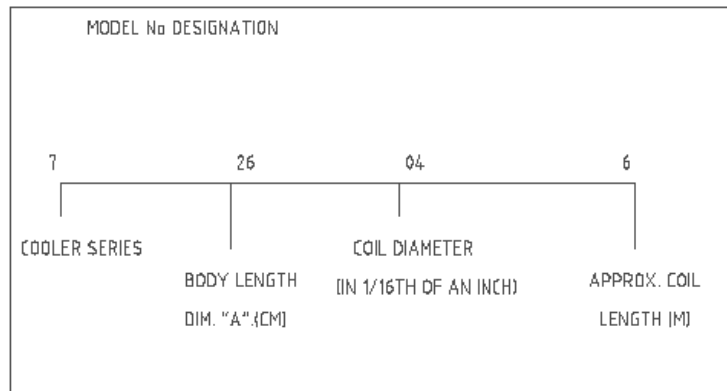



Sample Coolers

CALCULATIONS ARE BASED ON A COOLANT FLOW OF 2,400 L/HR
 WITH 35 DEG C INLET TEMPERATURE
 THE PERFORMANCE IS WITH A FOULING RESISTANCE OF
 0.059m² °K/kW ADDED TO BOTH SIDES OF THE COOLING ELEMENT

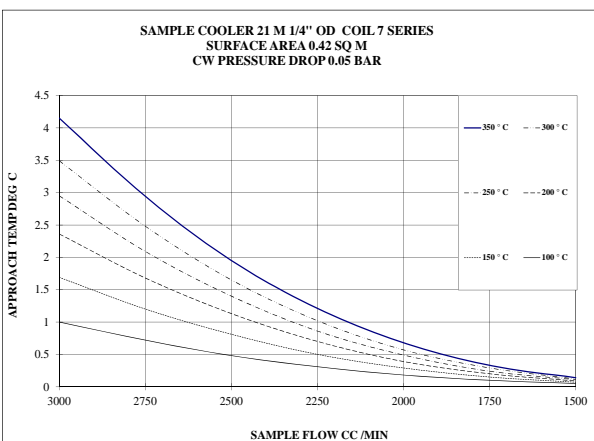
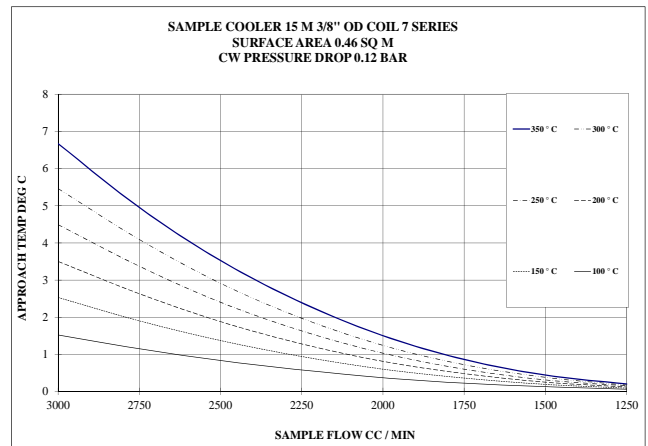
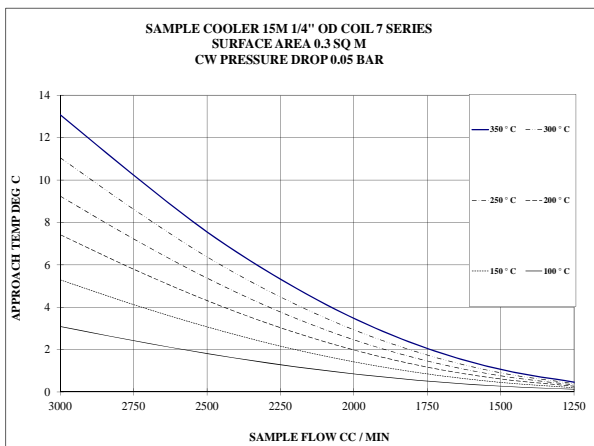
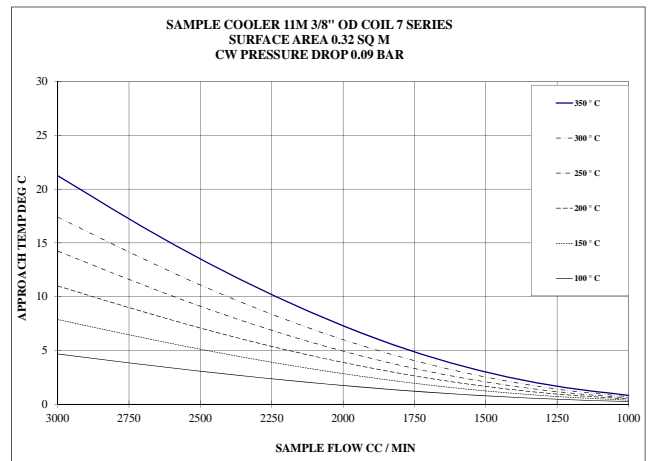
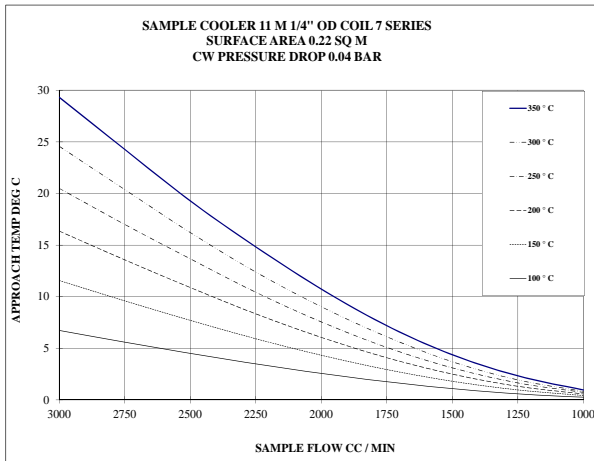
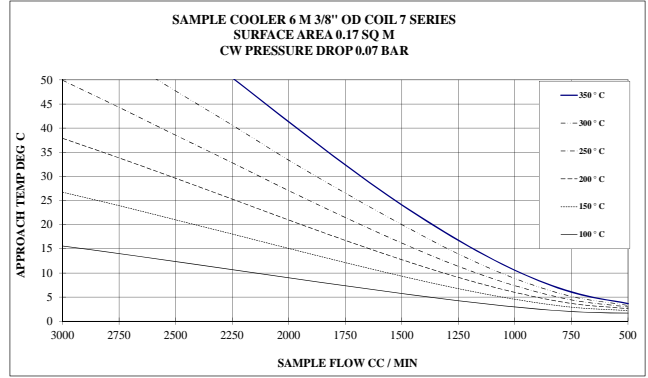
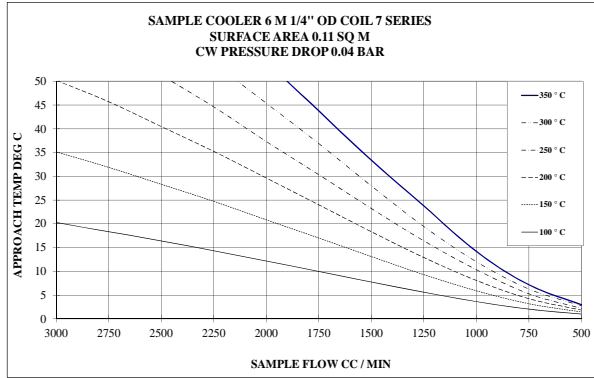

Cooler Performance Table for Steam

The Table shows the Sample Outlet temperature

Basis of Calculation is Coolant inlet 35 °C Flow 2,400 L/hour

Fouling Factors 0.059 Both Sides Coolant and Sample

		300 °C			250 °C			200 °C			
		86 BARA			40 BARA			16 BARA			
Samples		7.26		7.35	7.26		7.35	7.26			
Sample Flow mL/Min	Cooler Model	04.6	06.6	06.11	04.15	04.6	06.6	06.11	04.15	06.6	06.11
	500		41	42	36	35	42	42	35	35	46
1000		64	60	37	36	60	68	38	36	99	39
1500		103	90	41	37	90	120	46	38	XXX	XXX